

Technical characteristics

- Flow rates: from 0.4 to 54 l/h
- Max back pressure: up to 20 bar
- Power supply:
 - 100÷240 Vac - 50/60 Hz
 - 24÷48 Vac/Vdc (only MKL603)
- Stroke rate: from 120 to 300 strokes/minute
- Pump head:
 - PVDF
- Diaphragm: PTFE
- External Enclosure: PP reinforced with fiber glass
protection degree IP65
- Manually priming valve
- Installation kit: Included

Seko Maxima EVO MKL Series is a base analogic dosing pump with constant flow rate, which is manually adjustable by a knob mounted on the panel.

The flow rate has two frequency ranges:

- 0÷20 % of max flow rate
- 0÷100% of max flow rate

With only 5 sizes that pump can cover a wide range of performances, having a flow rate range from 0.4 to 54 l/h and a back pressure from 0.1 to 20 bar. The power supply is 100÷240 Vac – 50/60 Hz therefore the same pump can operate with different supply voltage, moreover the model MKL603 have the possibility for 24÷48 Vac/Vdc power supply.

The standard pump head is in PVDF, therefore high chemical compatibility with several liquids end .

All Maxima EVO Series are equipped with a manually priming pump for the start up.

The pump is furnished with a complete standard installation kit, which includes: PVDF foot filter and injection valve, PVC suction tube, PE delivery tube.

PUMP KEY CODE

1°	Model				
MKL	Analog dosing pump with constant flow rate manually adjustable. Two frequency range: 0÷20% and 0÷100% of max flow rate, level control input, Power ON led indicator.				
2°	Hydraulic				
Model	Pressure [bar]	Flow rate [l/h]	Stroke/min	cc/stroke	
500	20	0,4	120	0,06	
	16	0,8		0,11	
	10	1,2		0,17	
	6	15		0,21	
600	20	2,5	120	0,35	
	18	3		0,42	
	14	4,2		0,58	
	8	7		0,97	
603N	12	4	160	0,42	
	10	5		0,52	
	8	6		0,63	
	2	8		0,83	
603O	7	2	160	0,21	
	5	6		0,62	
	0,2	15		1,56	
800	16	7	300	0,39	
	10	10		0,55	
	5	15		0,83	
	1	18		1,00	
803	5	20	300	1,11	
	4	25		1,39	
	2	38		2,11	
	0,1	54		3,00	
3°	Stroke Regulation				
N	NO Regulation				
4°	Power supply				
N	100÷240 Vac - 50/60 Hz				
O	24÷48 Vac - 50/60 Hz (only for APG603)				
5°	Liquid end				
	Pump head	Connection	Balls	Diaphragm	
H	PVDF	PVDF	Ceramic	PTFE	
P*	PVC	PVC	Ceramic	PTFE	
	*Head pump with automatic degassing valve, only for 603 and 800 series				
6°	Installation kit				
H	PVDF				
7°	Seals				
0	FPM				
1	EPDM				
8°	Market				
0	Standard				
9°	RAL color				
	Hydraulic	Electronic			
B	5010	7004			
10°	Optional				
0	Standard				

MKL	600	N	N	H	H	1	0	B	0
-----	-----	---	---	---	---	---	---	---	---

HYDRAULIC CHARACTERISTICS

Pump Model	Pressure [bar]	Flow Rate [l/h]	Frequency max [stroke/min]	Stroke capacity [cc/stroke]	Connection [mm]		Power supply	Consumption [W]	
					Suction	Discharge		Min*	Max
MKL500N	20	0,4	120	0,06	4/6	4/7	100÷240 Vac	8	14
	16	0,8		0,11					
	10	1,2		0,17					
	6	1,5		0,21					
MKL600N	20	2,5	120	0,35	4/6	4/7	100÷240 Vac	8	15
	18	3		0,42					
	14	4,2		0,58					
	8	7		0,97					
MKL603N	12	4	160	0,42	4/6	4/6	100÷240 Vac	15	18
	10	5		0,52					
	8	6		0,53					
	2	8		0,63					
MKL603O	7	2	160	0,21	4/6	4/6	24÷48 Vac	17	17
	5	6		0,62					
	0,2	15		1,56					
MKL800N	16	7	300	0,39	4/6	4/6	100÷240 Vac	15	26
	10	10		0,56					
	5	15		0,83					
	1	18		1,00					
MKL803N	5	20	300	1,11	8/12	8/12	100÷240 Vac	15	25
	4	25		1,39					
	2	38		2,11					
	0,1	54		3,00					

*Minimum consumption at 0 bar of backpressure (Patented)

MKL

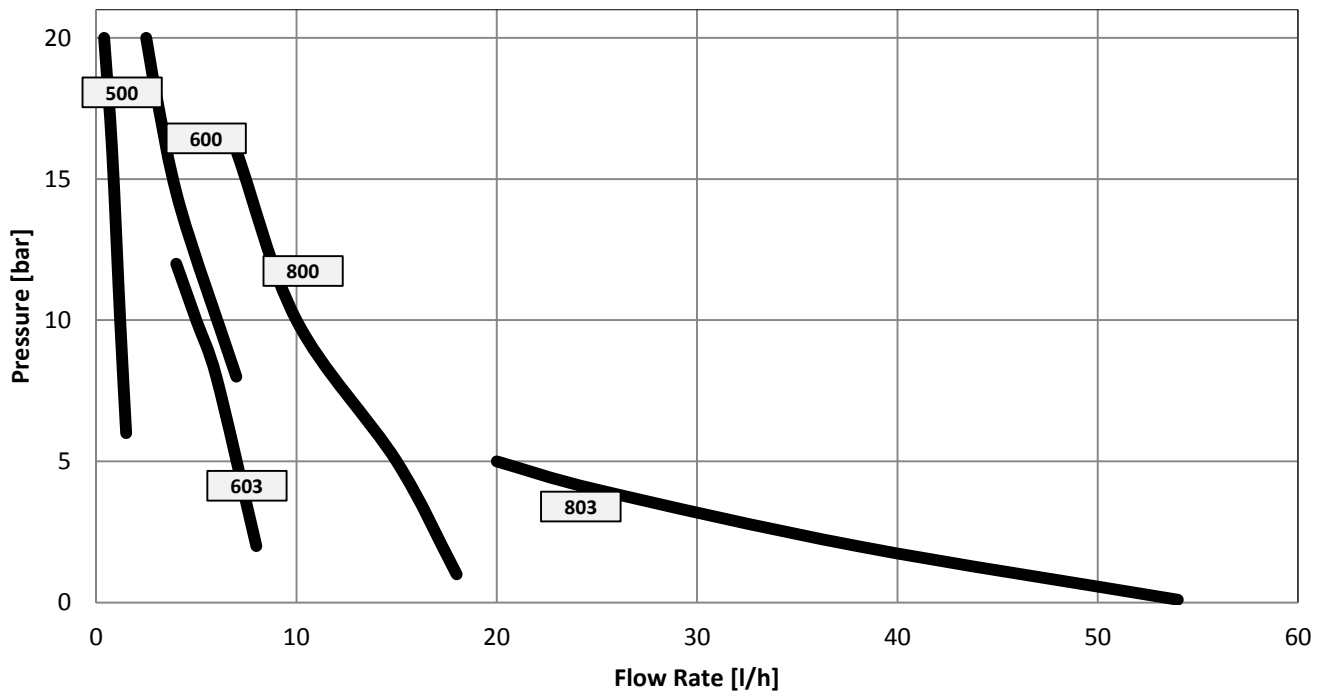

DIMENSIONS

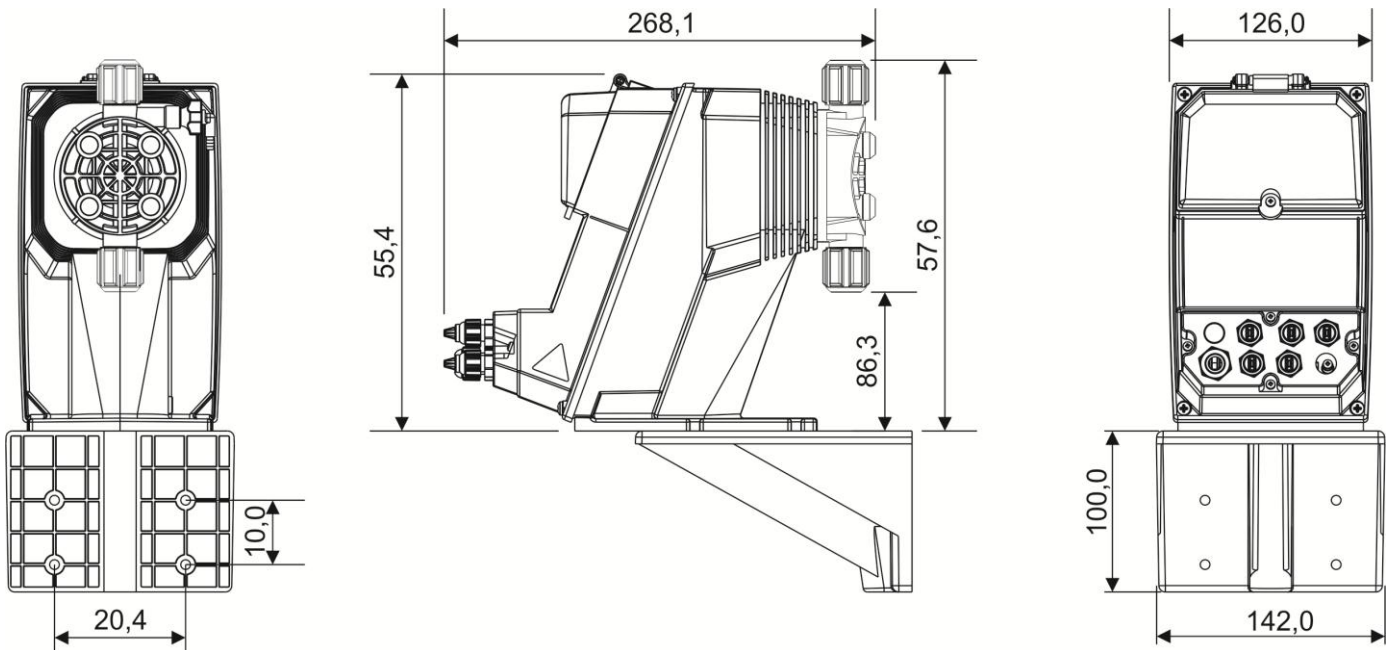

INSTALLATION KIT

- PVDF foot filter
- PVDF injection valve
- PVC suction tube (4 m)
- PE delivery tube (2 m)

WALL FIXING BRACKET AVAILABLE

